

**INTERNATIONAL JOURNAL OF ENGINEERING SCIENCES & RESEARCH
TECHNOLOGY****PROTECTION SCHEME FOR FIXED SERIES COMPENSATING DEVICES USING
MOV AND SPARK GAP****Prof. Piyush Khadke*¹, Dr. Nita Patne², Ms. Monica Shelke³**^{*1} Assistant Prof., Department of Electrical Engineering, Ramdeobaba College of Engineering and Management, Nagpur, India- 440013² Assistant Prof., Department of Electrical Engineering, Visvesvaraya National Institute of Technology, Nagpur, India- 440010³ PG Scholar, Department of Electrical Engineering, Visvesvaraya National Institute of Technology, Nagpur, India- 440010

DOI: 10.5281/zenodo.1036575

ABSTRACT

Increasing power demands globally need a scheme which will increase the transmission capacity of existing power transmission lines economically. Nowadays use of FSC (Fixed Series Compensation) has been turned into a common practice in power industries as a compensation device. In this paper, the FSCs behavior under different types of faults is simulated. Under faulty condition the FSC is subjected to the over-voltages. Many protection schemes for series capacitor under overvoltage condition are limited in terms of performance under different environmental conditions and also in terms of size. There is a need for environmentally robust and more compact in size equipment. In this paper, emphasis is given on the series capacitor protection. The effectiveness of the protection scheme, which is valid for different types of TL faults, is demonstrated by comparing the results. The simulation study for single phase and three phase to ground fault is carried out using MATLAB/Simulink.

KEYWORDS: Fixed Series Compensation (FSC), Metal Oxide Varistor (MOV), Spark Gap, Transmission Line (TL)**I. INTRODUCTION**

A worldwide trend in the development of power transmission system is to built interconnections by achieving economical benefits because of the highly increasing costs of building new TL, compounded by the difficulty to obtain Right of Way (RoW) [1]-[3]. The use of series capacitor has been proved to be an effective means of compensation device for compensating the inductive reactance of TLs thereby increasing the power transmission capacity [4]-[5]. Also, at a given level of power transfer a reduction in the power transmission angle and an increased virtual natural load, this makes series capacitor a common choice in power transmission industries [6]-[8].

Since the early part of the 20th century, the series compensation has been in use. The application of Series Capacitor Banks dates back to 1928 when the first bank at the Ballston Spa Substation on the New York Power and Light 33 kV grid were installed by GE. The bank was rated for 1.2 MVar. Since then, the series capacitor banks have been installed on power systems all over the world [9]. For the EHV power transmission, the first series capacitor was installed in Sweden in 1951 for 245 kV TL [10]. 400 kV series compensation was implemented firstly in Sweden in 1954 [11]. In the USA in 1951, the similar project was implemented [12]. The first 500 kV series compensation in USA, was introduced in 1960s [13]. Important projects on series compensation have been implemented in other countries such as Mexico, Brazil, the USSR, Argentina, China, India and many others. Hydro-Quebec, in Canada is planning to install series compensation on several lines of its 735 kV power transmission grid [10].

FSC techniques are the simplest and most cost effective to achieve higher transmission capacity of the UHV grid and, therefore, the return on the capital investment, enhance system stability, improve system operation voltage and voltage distribution along transmission lines, realizes resource allocation in a wide range and ensure

safe and stable operation of power grid if power system damping and Sub synchronous resonance (SSR) mitigation are not of a concerned topics. This scheme utilizes the capacitors of fixed value which are placed in series with the transmission line in order to cancel a portion of the inductive reactance and thereby achieving the desired increase in transmission capacity [14]-[16]. The risk of power oscillations can be reduced by reducing the impedance between generators or networks involved in the oscillation, this is where the use of FSC in general can be stated [17].

For the above mentioned reasons, the use of FSC have become more common in transmission lines where the distances between load centers is more and large investments are required. The FSCs are composed of several equipments those are exposed to overvoltages of different origin, with the most dangerous resulting from internal and external transmission line faults. Without counter measures, the occurrence of these overvoltages in transmission system can be dangerous to the FSC leading to its insulation breakdown and failure [18].

Thus, there is a need for a scheme to protect series capacitor against overvoltages. In modern installations, traditional gap type scheme has been replaced with highly non- linear Metal Oxide Varistor (MOV) which bypasses series capacitor in the event of overvoltages. The main advantage of this scheme is that the series capacitor during a fault is not entirely bypassed, thus reinsertion is instantaneous without transients.

The purpose of this paper is to evaluate the FSCs protection through a system modeling and the analysis through simulations for different type of faults, thus allowing prediction of the level of short circuit currents and the energy absorbed by the MOV.

A. Model Configuration:

The main component of a FSC include capacitor bank and a MOV (Metal Oxide Varistor) assembly in parallel, all in parallel with a triggered Spark Gap in series with RL damping circuit and a Bypass Switch/ Bypass Circuit Breaker as shown in Fig. 1.

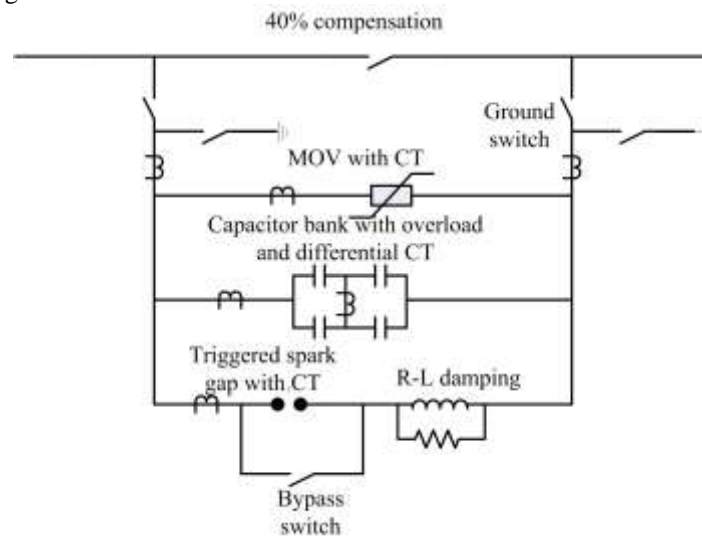

Fig. 1. FSC Single Line Diagram

1) Capacitor Bank:

The series capacitor banks are generally located at either end of the section of the transmission line in one of the existing substations. However, sometimes FSCs are located near the middle of the transmission line section which reduces the worst case potential fault current and thus, the same case is used for simulating the model in this paper. Therefore, with lower potential fault current, the MOV bank can be designed smaller [9].

2) Metal Oxide Varistor (MOV):

In case of an overvoltage, the arrangement of the MOVs in parallel with a capacitor bank lead to an uneven current distribution between them, which is caused due to the high degree of non-linearity of that part of the voltage-current characteristic where the MOVs have to operate in case of a system fault.

There are two different types of faults which have to be considered while designing the number of MOV housings:

External Faults:

External faults are those occurring outside the series compensated transmission line protected and terminated by circuit breakers. The MOVs must be designed to withstand these faults without damages since the FSC is not allowed to be bypassed during external faults [19].

The maximum MOVs current and energy accumulated by MOV during external faults are used as criteria to distinguish between internal and external TL faults [20]. In this paper 8 kA as maximum MOV current and 30 MJ as maximum energy to be accumulated, are considered as deciding criteria.

Internal Faults:

Internal faults are those occurring inside the circuit breaker protected series compensated TL. As soon as internal fault is detected, the series capacitor is allowed to be bypassed by means of the Triggered Spark-Gap. Overvoltage stress is maximum on MOV and capacitor in these type of faults.

3) Triggered Spark-Gap:

The spark gap is used to protect the MOV and in turn FSC against overvoltage in the event of internal faults. As soon as a threshold value of 8 kA is exceeded, protection fires the gap within 1 msec. It is required that the gap bypasses the MOV as soon as possible since rate of rise of energy dissipation is very high in MOV during internal faults [21].

4) R-L Damping Circuit:

R-L damping system basically is a current limiting circuit, consisting of an inductor in parallel with resistor. For the event of an internal faults, the damping circuit is designed in such a way that the capacitor discharges through it when the voltage across the FSC reaches the protective level. When the gap fires, this circuitry causes the current to limit at a particular frequency that depends on the value of inductance and capacitance of the circuit [21].

5) Bypass Switch:

Also called as Bypass Circuit Breaker used for insertion and disconnection of the FSC. In case of an internal faults, it closes to relieve the gap from further current stresses by allowing the gap current to commute through it. The protection system also closes the switch if the rated MOV energy is exceeded.

B. Transmission Line Model with Series Compensation:

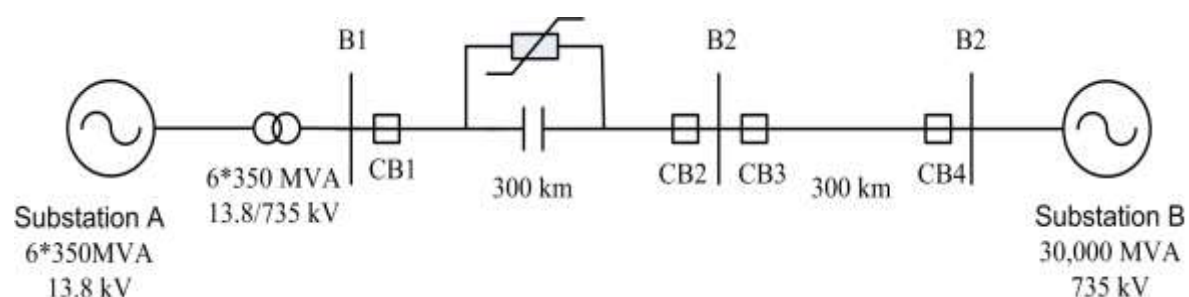

Fig. 2. Series Compensated Transmission Line

The system in Fig. 2 is used for analysis using MATLAB/Simulink. The active power P transferred by the series compensated TL can be given as,

$$P = \frac{E_s * E_r}{X_t - X_c} \sin(\delta) \quad (1)$$

Where,

E_s = Sending end Voltage,
 E_r = Receiving end Voltage,
 δ = angle between voltages,
 X_l = Total Line Reactance,
 X_c = Series Capacitor Reactance

A 3-phase, 60 Hz, 735 kV power system transmitting the power through a 600 km transmission line is considered for analysis purpose where the transmission line is split in two 300 km lines connected between the three buses B1, B2, and B3 as shown in figure. While modeling, each segment of the line is compensated with series capacitor and degree of compensation used is 40%. The series compensation subsystems are identical for both the line segments. The various simulation parameters used are given in following tables.

Table 1. Transmission line parameters

Parameter	Value	Unit
Positive-sequence resistance R_1	0.01273	Ω/km
Zero-sequence resistance R_0	0.3864	Ω/km
Positive-sequence inductance L_1	0.9337×10^{-3}	H/km
Zero-sequence inductance L_0	4.1264×10^{-3}	H/km
Positive-sequence capacitance C_1	12.74×10^{-9}	F/km
Zero-sequence capacitance C_0	7.751×10^{-9}	F/km
Line voltage	735	kV
Line length	300	km
System frequency	60	Hz

Table 2. Source parameters

Parameter	Value	Unit
Source Voltage	735	kV
Short circuit level	30000	MVA

Table 3. SC/MOV specifications

Compensation (K) (%)	I_{ref} (KA)	X_c (Ω)	$V_{ref} = \sqrt{2} I_{ref} X_c$ (kV)
40	2	42.24	298.7

II. SIMULATION RESULTS

Simulation results for single phase to ground fault and three phase to ground fault are presented in this paper which describes the performance of protection scheme under different fault condition.

A. Single Phase to Ground Fault

The single phase to ground fault is simulated on the model shown in Fig. 2, where the fault is applied on phase A at $t = 0.0167$ sec. Circuit breakers which were initially closed, after occurrence of fault, relay opens up the two line circuit breakers at $t = 0.0833$ sec (i.e. after five cycles). And fault is cleared at $t = 0.1$ sec, one cycle after line opening. Fig. 3 illustrates that when a line to ground fault is applied the fault current reaches 10 kA.

In this simulation, MOV current of 8 kA has been stated for the protection system parameter to detect internal faults. Ideally, capacitor bank would be bypassed but it is not happening here, since fault is not detected as an internal due to MOV current is slightly lower than the protection setting of 8 kA.

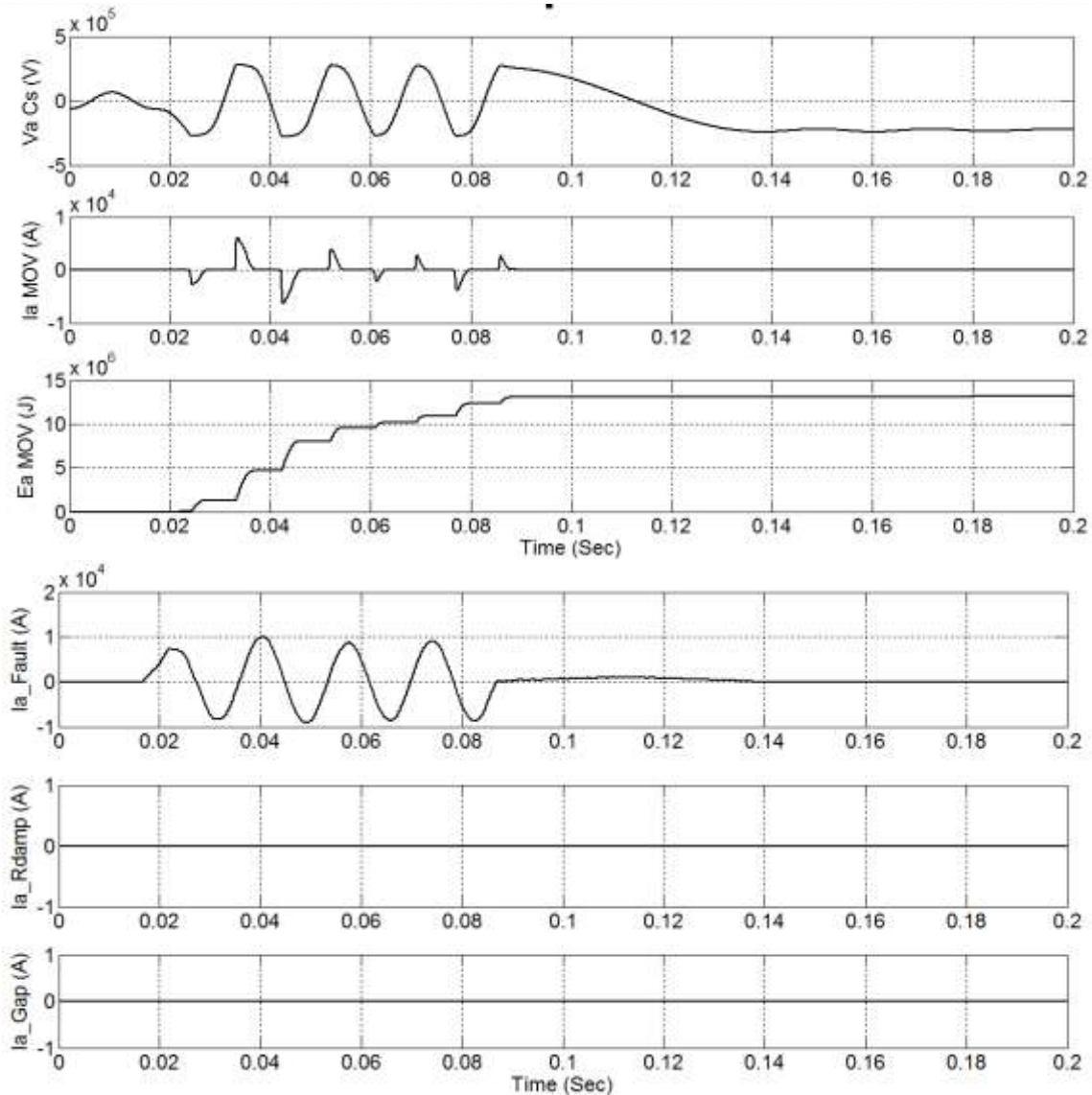

Fig. 3. Single Phase to Ground Fault

MOV conducts for every half cycle during the fault and energy dissipated in the MOV builds up to 13 MJ which is lower than the threshold level of 30 MJ and thus, the gap is not fired and also RL damping circuit is not conducting.

At $t = 0.0833$ sec relays open up the two line circuit breakers and the MOV energy stays constant at 13 MJ. After circuit breaker opening the fault current drops to a small value, transmission line and series capacitor initiate to discharge through the fault path and shunt reactance. At the first zero crossing after the opening order given to the fault breaker i.e. at $t = 0.1$ sec, the fault current extinguishes and then the series capacitor stops discharging and its voltage oscillates around 300 kV.

B. Three Phase to Ground Fault

The three phase to ground fault is applied on phase A at $t = 0.0167$ sec. Circuit breakers which were initially closed, after occurrence of fault, relay opens up the two line circuit breakers at $t = 0.0833$ sec (i.e. after five cycles). And fault is cleared at $t = 0.1$ sec, one cycle after line opening. Fig. 4 illustrates that when three line to ground fault is applied the fault current reaches 14.7 kA and two cycles before the opening of line breakers ($t = 0.0833$ sec), MOV energy reaches its threshold level of 30 MJ. As soon as the instantaneous value of the MOV current exceeds 8 kA, the protection system issues a signal to trigger the gap and thus the air gap is fired, as shown in Fig. 4 and voltage across series capacitor for all the three phases immediately falls to zero through RL damping circuit.

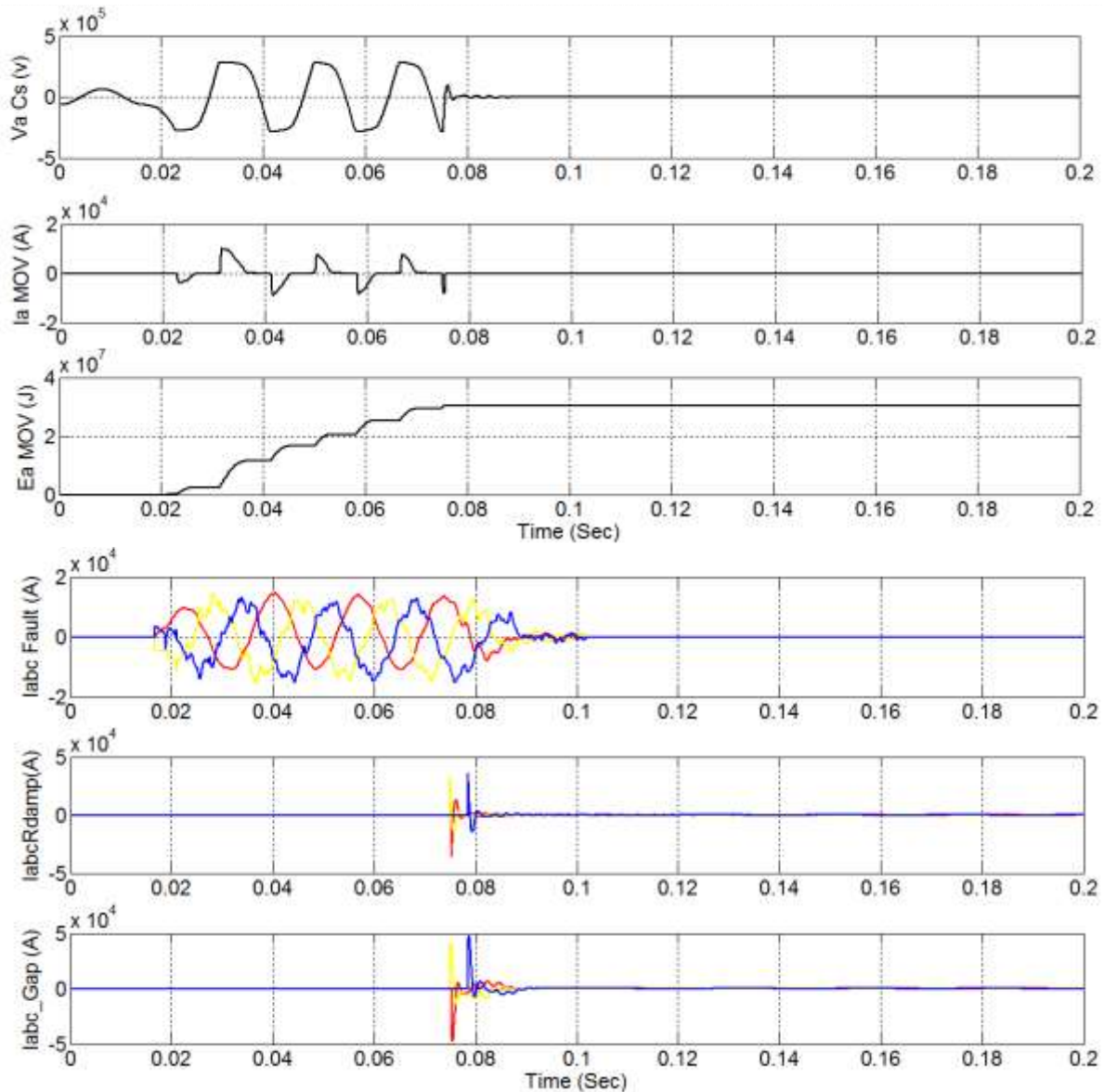

Fig. 4. Three Phase to Ground Fault

9pt Times New Roman, Bold, Italic

Sub-subheading

Sub-subheading should be 10pt Times new roman, Italic, Justified.

III. RESULTS AND DISCUSSION

During single phase to ground fault, capacitor is not fully bypassed from the system, whereas during three phase to ground fault the protection devices operates immediately with the severity of the fault, in order to bypass the capacitor from the system and to provide overvoltage protection to capacitor. Since, the capacitor is not isolated from the system, its reinsertion is instantaneous.

Due to non linear characteristics of the MOV, it provides high impedance path when series capacitor voltage is less than its protective level and thus current through the MOV is zero. Series capacitor conducts current first which is then diverted to MOV for remaining half cycle, which happens for every half cycle of the current. It is to be noted that the energy across MOV in faulted phase is in MJ whereas in mJ in healthy phase. Thus, it can be said that deciding factor for firing of spark gap is energy dissipation across MOV.

IV. CONCLUSION

FSC protection has been realized by the MOVs, Triggered Spark-Gap and Bypass switch using MATLAB/Simulink. Power transmission lines fault simulations were realized through modeling to evaluate the protection performance of FSC. In this paper, many different types of faults like external and internal faults were carried on, but only most significant results were presented. It is observed that having this scheme in the system makes removal and insertion of series capacitor instantaneous without any transients. From the results it is found that the protection scheme for FSC was effective and basic FSC design settings were proven to be correct.

V. ACKNOWLEDGEMENTS

The authors would like to thank Electrical Engineering Department., Visvesvaraya National Institute of Technology, Nagpur (India) for providing required research infrastructure for this research.

VI. REFERENCES

- [1] A. Sitnikov, D. Povh, D. Retzmann and E. Teltsch, "Solutions for Large Power System Interconnections", in CIGRE Conference for Synchronous Operation of the East-West Interconnection in Europe, S1. Petersburg, Russia, 2003.
- [2] P. Kundur, Power System Stability and Control. New York: Mc-Graw Hill, 1994.
- [3] J. D. Glover and M. S. Sarma, "Power Systems: Analysis and Design. Pacific Grove", CA: Brooks/Cole - Thomson Learning, 2010.
- [4] S. Henschel, L. Kischner, and M. C. Lima, "Transient Recovery Voltage at Series Compensated Transmission Lines in Piauí, Brazil", Proceedings of the International Conference on Power System Transients (IPST'05), pp. 1-6, June 2005.
- [5] D. McNabb, M. Granger, Q. B. Van, M. Rousseau, and M. Pilot, "Transient Design Studies for the Transmataro Series-Compensated Transmission System", Proceedings of the International Conference on Power System Transients (IPST'01), pp. 1-6, June 2001.
- [6] ABB Metal Oxide Surge Arresters – EXLIM P, ABB Electrical Apparatus, May 2005.
- [7] T. J. Miller, Reactive Power Control in Electric Systems. New York: Wiley-Interscience, 1982.
- [8] Q. Y. Xuan, A. T. Johns, "Digital Simulation of Series compensated EHV (Extra High Voltage) Transmission Systems", IEE Colloquium on Simulation of Power System, 1992.
- [9] J. Woodworth, "MOV protection of series capacitor banks", Arrester Factors008, 2008.
- [10] Available at http://arresterworks.com/ArresterFacts_files/ArresterFacts%20008%20%20MOV%20Protection%20of%20Series%20Capacitor%20Banks.pdf
- [11] M. Courwl & C.T. Nguyen, I Lord, X -11 Do, "Modeling MOVProtected Series Capacitors for Short-circuit Studies", IEEE Transaction5 on Power Delivery, Vol 8, January 1997.
- [12] R. Lord, "Validation d'un logiciel de court-circuits adapte pour la compensation serie", Hydro Quebec Internal Report, February 1989.
- [13] D.L.Goldsworthy, "A Linearized Model for MOV Protected Series Capacitors", I IEEE Transactions on Power Systems, Vol. PWR5-2, No 4, November 1987, pp. 953-958.
- [14] S. de Oliveira, etA1, "Representation of Series Capacitors in Electric Power System Stability Studies", paper presented at IEEE/PES winter meeting, New-York, Feb. 1991.
- [15] H. Chao, Chao Xia, X. Chen and R. Shen, "Protection of 1000kV Fixed Series Compensation against Lightning", International Conference on Lightning Protection (ICLP), Shanghai, China, 2014
- [16] C. Hor, J. Finn, G. Thumm and S. Mortimer, "INTRODUCING SERIES COMPENSATION IN THE UK TRANSMISSION NETWORK", Siemens Transmission and Distribution Ltd, United Kingdom
- [17] A. L.P. de Oliveira. "The design of 230kV Fixed Series Compensations Installed at Barra Do Peixe 230kV substation (Eletronorte)", XI SEPOPE, 16-20 March 2009, Brazil.
- [18] A. L. P. de Oliveira, "The Main Aspects of Fixed Series Compensation Dimensioning at Brazilian 230 kV Transmission System", Transmission and Distribution Conference and Exposition: Latin America, 2008 IEEE/PES
- [19] A. L.P. de Oliveira, "Fixed series compensation protection evaluation using transmission lines faults simulations", Transmission and Distribution Conference and Exposition: Latin America, 2008 IEEE/PES
- [20] G. Thumm and L. Kirschner, Rio Verde 230 kV Substation (FURNAS Centrais Eletricas S.A.) - Fixed Series Compensation - Basic Design Report, Power Transmission and Distribution - Reactive Power Compensation - PTD H 166, Erlangen, Germany, 2006

- [21] IEEE PxxxxTM/D7 - Draft Guide for the Specification of Fixed Series Capacitors Banks for Transmission System Applications, IEEE Standard PxxxxTM/D7 (draft), January 2007.
- [22] P.M. Anderson "Power System Protection" Wiley - Interscience, a John Wiley & Sons, Inc., Publication, Chapter-15 Series-Compensated Line Protection. Page no. 575-642.
- [23] P. Khadke, A. Tohare, N. Patne, G. Shinde "Fixed Series Capacitors for Increased Power Transmission Load ability of 400 KV Raipur – Wardha Corridor", IJSRD - International Journal for Scientific Research & Development, vol. 2, no. 1, pp. 178-182, April 2014.
- [24] P. Khadke, N. Patne, A. Singh and G. Shinde, "A soft computing scheme incorporating ANN and MOV energy in fault detection, classification and distance estimation of EHV transmission line with FSC", SpringerPlus, vol. 5, pp. Oct. 2016.

CITE AN ARTICLE

Khadke, P., Patne, N., Dr, & Shelke, M., Ms. (2017). PROTECTION SCHEME FOR FIXED SERIES COMPENSATING DEVICES USING MOV AND SPARK GAP. *INTERNATIONAL JOURNAL OF ENGINEERING SCIENCES & RESEARCH TECHNOLOGY*, 6(10), 579-586.